

ISOMAG ™

The friendly magmeter

ALPHANUMERIC CONVERTER

ML 110



ALPHANUMERICAL DISPLAY CONVERTER

Warranty conditions are available on this website:
www.isomag.eu only in English version

ISOIL 
INDUSTRIA
The solutions that count

TECHNICAL DATA

Suitable for	<input type="checkbox"/> All the ISOMAG sensors
Minimum conductivity	<input type="checkbox"/> 5 μ S/cm
Housing materials	<input type="checkbox"/> Nylon with fiber glass or Aluminium
Dimensions	<input type="checkbox"/> See Drawing
Protection rating	<input type="checkbox"/> IP 65/IP 67 (Aluminium housing)
Conn. sensor cable/Cable gland	<input type="checkbox"/> CABLE C018 / N° 3 CABLE GLAND PG 11
Ambient temperature	<input type="checkbox"/> 0... +60°C
LCD Display	<input type="checkbox"/> Alphanumerical display 16 characters x 2 lines no back light
Keyboard	<input type="checkbox"/> 3 internal keys
Pulses/frequency outputs	<input type="checkbox"/> N°2 , 1250 Hz, 100mA, 40 Vdc
Current output	<input type="checkbox"/> N°1 , 0/4...20mA – RL=800 Ω
Dig. Input / Alarm output	<input type="checkbox"/> Programmable function
Bi-directional	<input type="checkbox"/> Yes
Dual range	<input type="checkbox"/> Yes
Full Scale value	<input type="checkbox"/> 0,4...10 m/s
Communication port	<input type="checkbox"/> RS 485 (OPT.)
Protocols	<input type="checkbox"/> ETP (Standard) - Modbus (opt.)
Diagnostic funct.	<input type="checkbox"/> Yes
Empty pipe detect.	<input type="checkbox"/> Yes
Galvanic isolation	<input type="checkbox"/> All the inputs/outputs are galvanically isolated from power supply up to 500 V
Data storage	<input type="checkbox"/> Eeprom values storing system in case of power failure
Programming plug in	<input type="checkbox"/> Protected plug in for the connection to PC or hand terminal
CE certification	<input type="checkbox"/> Yes
Measurements tolerance	<input type="checkbox"/> Flow rate (volume) = $\pm 0,1\%$ v.l. <input type="checkbox"/> Out 4/20 mA = $\pm 0,12\%$ v.l. <input type="checkbox"/> Frequency Out = $\pm 0,12\%$ v.l.
Repeatability	<input type="checkbox"/> Better than $\pm 0,2\%$
Accuracy	<input type="checkbox"/> See table below
Altitude	<input type="checkbox"/> -200 m up to 6000 m
Power supply/Consumption	<input type="checkbox"/> 90÷265 VAC(5VA) – 45÷66 Hz; 18÷63VDC/15÷45 VAC -45÷66Hz (4 VA - AC) / (3 W - DC)

OVERALL DIMENSIONS

COMPACT VERSION (NYLON)

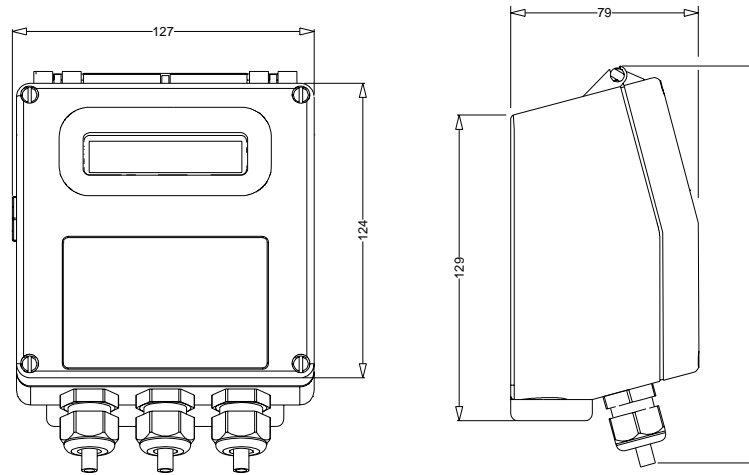

COMPACT VERSION (ALUMINIUM)

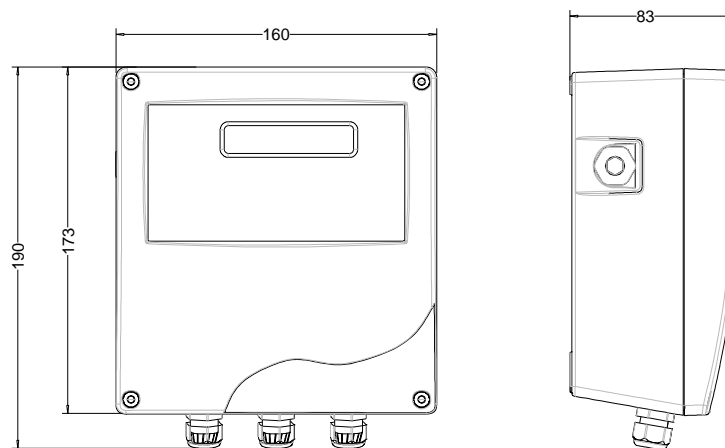

SEPARATE VERSION

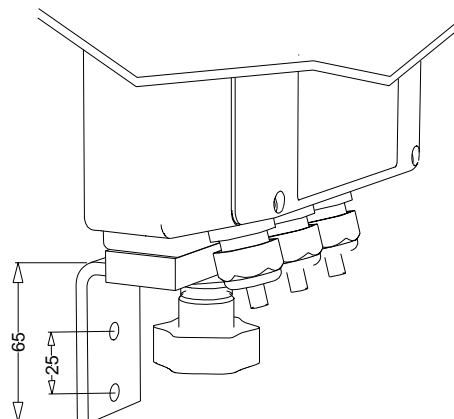

VISUALIZATION PAGES

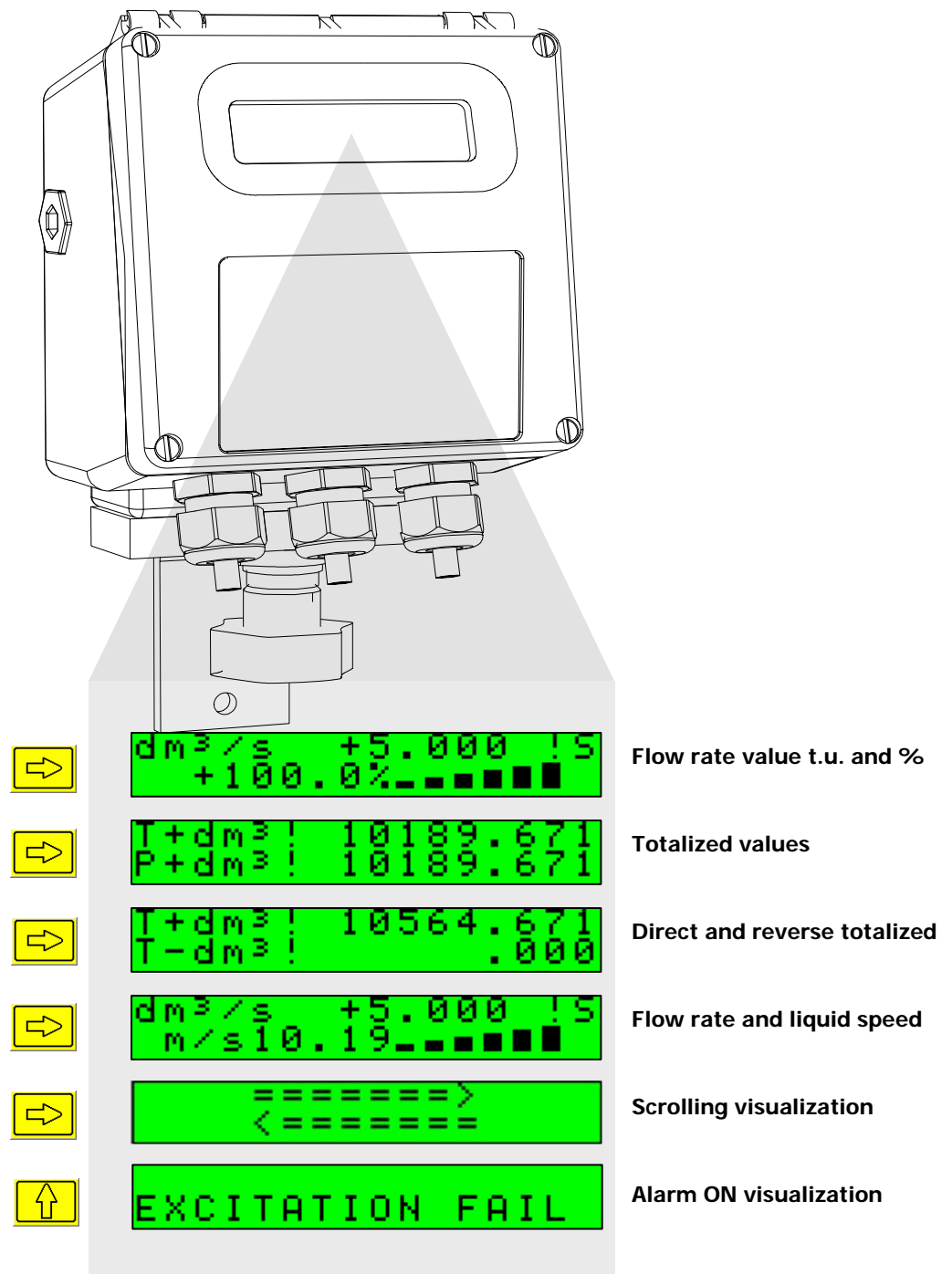

Different visualization possibilities with a simple press of a key

ELECTRICAL CONNECTIONS

TERMINAL BLOCK VIEW

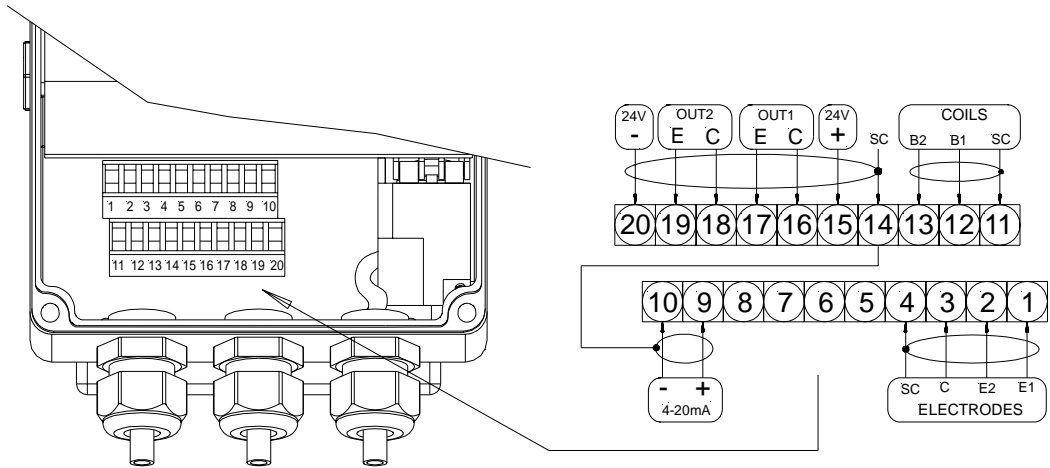

ON/OFF OUTPUT

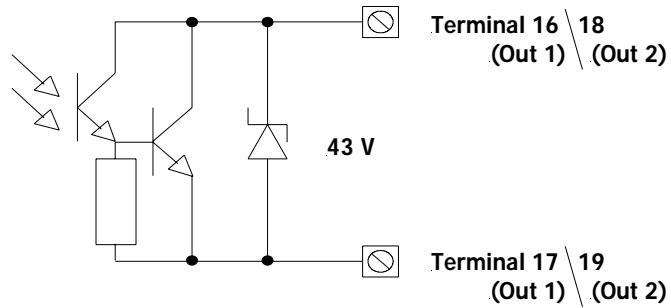

ANALOG OUTPUT

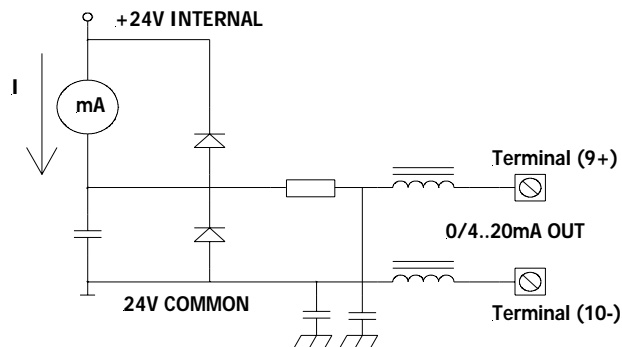

FUNCTIONS

MAIN MENU 1-Sensor

```

1-SENSOR
ND=mm      00025
KA=        +01.0000
Sens.type= 00
Ins.position= 0
KL=[0]    +00.0000
KL=[0]    +00.0000
E.P.detect= OFF
E.P.thr.=  200
Autozero cal.

```

- 1.1 Nominal Diameter (ND) of sensor, (enter input value 0-3000 mm)
- 1.2 Sensor calibration data (Enter value as specified on sensor label)
- 1.3 Type of sensor: Enter the first two characters of the sensor serial number
- 1.4 Position of insertion sensor: 0=1/8DN, 1=1/2DN, 2=7/8DN
- 1.5 Factory parameters
- 1.6 Enables the empty pipe detection feature
- 1.7 Value of empty pipe sensibility detection
- 1.8 Enables the automatic calibration procedure for empty pipe detection

MAIN MENU 2-Scales

```

2-SCALES
Fs1=dm³/s  05.000
Fs2=dm³/s  05.000
Tot.MU=dm³  1.000
Pls1=dm³   01.0000
Pls2=dm³   01.0000
Tpls1=ms   0050.00
Tpls2=ms   0050.00
Frs1=Hz    01000.00
Frs2=Hz    01000.00

```

- 2.1* Full scale value set for range N.1 (function info & modification page 22)
- 2.2* Full scale value set for range N.2
- 2.3* Unit of measure and number of decimal place (Info & modification page 23)
- 2.4* Pulse value on channel 1 (Function Info & modification page 23)
- 2.5* Pulse value on channel 2 (Function Info & modification page 23)
- 2.6* Duration of the pulse generated on channel 1 (Info & modification page 23)
- 2.7* Duration of the pulse generated on channel 2 (Info & modification page 23)
- 2.8 Full scale frequency for channel 1 (0.1Hz-1000.0Hz)
- 2.9 Full scale frequency for channel 2 (0.1Hz-1000.0Hz)

MAIN MENU 3-Measure

```

3-MEASURE
Tconst=s   0002.0
Skip thr=% 025
Peak thr=% 125
Cut-off=%  07.0
Filter=s    0.2
Autocal.=  OFF
Autorange= ON
E.saving=  OFF

```

- 3.1* Time constant (function info & modification page 23)
- 3.2* Acceleration threshold (function info & modification page 23)
- 3.3* Anomalous signal peak cut off threshold (Info & modification page 24)
- 3.4 Low flow zero threshold: 0-25% of full scale value
- 3.5 Filter on the power supply: 0.1s="ready" measure: 0.5s=filter of noise on the liquid
- 3.6 Enable automatic hourly internal calibration cycle. Measurement stopped for 8-15s.
- 3.7* Automatic change of scale (function info & modification page 24)
- 3.8* Energy saving function (function info & modification page 24)

MAIN MENU 4-Alarms

```

4-ALARMS
Max thr=%  000
Min thr=%  000
Hyst.=%    03
E.P.thr.=  075
mA v.fault=% 010
Hz v.fault=% 125

```

- 4.1 Maximum flow rate value alarm setting
- 4.2 Minimum flow rate value alarm setting
- 4.3 Hysteresis threshold setting for the minimum and maximum flow rate alarms
- 4.4 Empty pipe detection threshold. Automatically set by the function 1.9
- 4.5* Current output value in case of failure (function info & modification page 24)
- 4.6* Frequency output value in case of failure (function info & modification page 25)

MAIN MENU 5-Inputs

```

5-INPUTS
T+ reset=  OFF
P+ reset=  OFF
T- reset=  OFF
P- reset=  OFF
Count lock= OFF
Calibration= OFF
Range change= OFF

```

- 5.1* Total direct (positive) flow totalise reset enable
- 5.2* Partial direct (positive) flow totalise reset enable
- 5.3* Total reverse (negative) flow totalise reset enable
- 5.4* Partial reverse (negative) flow totalise reset enable
- 5.6 Totalise counting lock command (see page 10)
- 5.7* Autozero calibration external command
- 5.9 Range change external command

MAIN MENU
6-Outputs

```
6-OUTPUTS
Out1= #1 FREQ
Out2= #2 FREQ+
Duty cycle1=% 50
Duty cycle2=% 50
Out mA1=4.22
```

- 6.1* Output 1 functions (function info & modification page 25)
- 6.2* Output 2 functions (function info & modification page 25)
- 6.3* Duty cycle value for pulses/frequency output (Info & modification page 26)
- 6.4* Choice of function the range of current output n.1 (Info & modification page 26)

MAIN MENU
7-Communication

```
7-COMMUNICATION
IF2 Prot.= DPP
Address= 000
RS485 bps= 4800
A.delay=ms 0
```

- 7.1 Choice of the communication protocol for the IF2 device
- 7.2 Address value of converter (range 0 - 255)
- 7.3 Speed of the RS485 output (possible choices: 2400, 9600, 19200, 38400 bps)
- 7.4 Instruments answer delay

MAIN MENU
8-Display

```
8-DISPLAY
Language= EN
D.rate=Hz 1
Contrast= 7
Quick start= OFF
Tot.modif.= OFF
Net total.= OFF
T+ reset
P+ reset
T- reset
P- reset
Currency= ON
Curr.decim.= 2
EUR/dm³+ 01.0000
EUR/dm³- 01.0000
```

- 8.1 Choice of the language: EN= English, IT=Italian, FR= French, SP= Spanish
- 8.2 Display update frequency: 1-2-5-10 Hz
- 8.3 Display contrast
- 8.4 Quick start menu visualization
- 8.5* Enable the change value of the totalises (info & modification page 27)
- 8.6 Enable the page of net totalizer
- 8.7* Total direct (positive) flow totalise reset (info & modification page 27)
- 8.8* Partial direct (positive) flow totalise reset (info & modification page 27)
- 8.9* Total reverse (negative) flow totalise reset (info & modification page 27)
- 8.10* Partial reverse (negative) flow totalise reset (info & modification page 27)
- 8.11 Visualizes the values of the partial totalise in the unit of selected currency
- 8.12 Choice of the numbers of decimals for the visualization currency value: From 0 to 3
- 8.13* Value of conversion/currency for direct totalizer (info & modification page 27)
- 8.14* Value of conversion/currency for reverse totalizer (info & modification page 27)

MAIN MENU
10-Diagnostic

```
10-DIAGNOSTIC
Calibration
Self test
Simulation= OFF
```

- 10.1* Calibration of the converter (single occurrence each time function is selected)
- 10.2* Converter auto test (single occurrence each time function is selected)
- 10.3* Flow rate simulation enabling

MAIN MENU
11-Internal data

```
11-INTERNAL DATA
L2 keycode=00000
Load fact.pres.
Load user pres.
Save user pres.
Hours= 000031
Ign.cal.err= OFF
KS= +1.0000
```

- 11.1 Level 2 access code enter (user choice and setting of access code if required)
- 11.2 Load factory data pre-set
- 11.3 Load user data saved
- 11.4 Save user data
- 11.5 Visualisation of the total operation hours of the converter (function not editable)
- 11.6 Ignore the calibration error during the switch on test (enable/disable)
- 11.7 KS Coefficient

Note : all page number references are to the operating manual .

ACCURACY TABLE

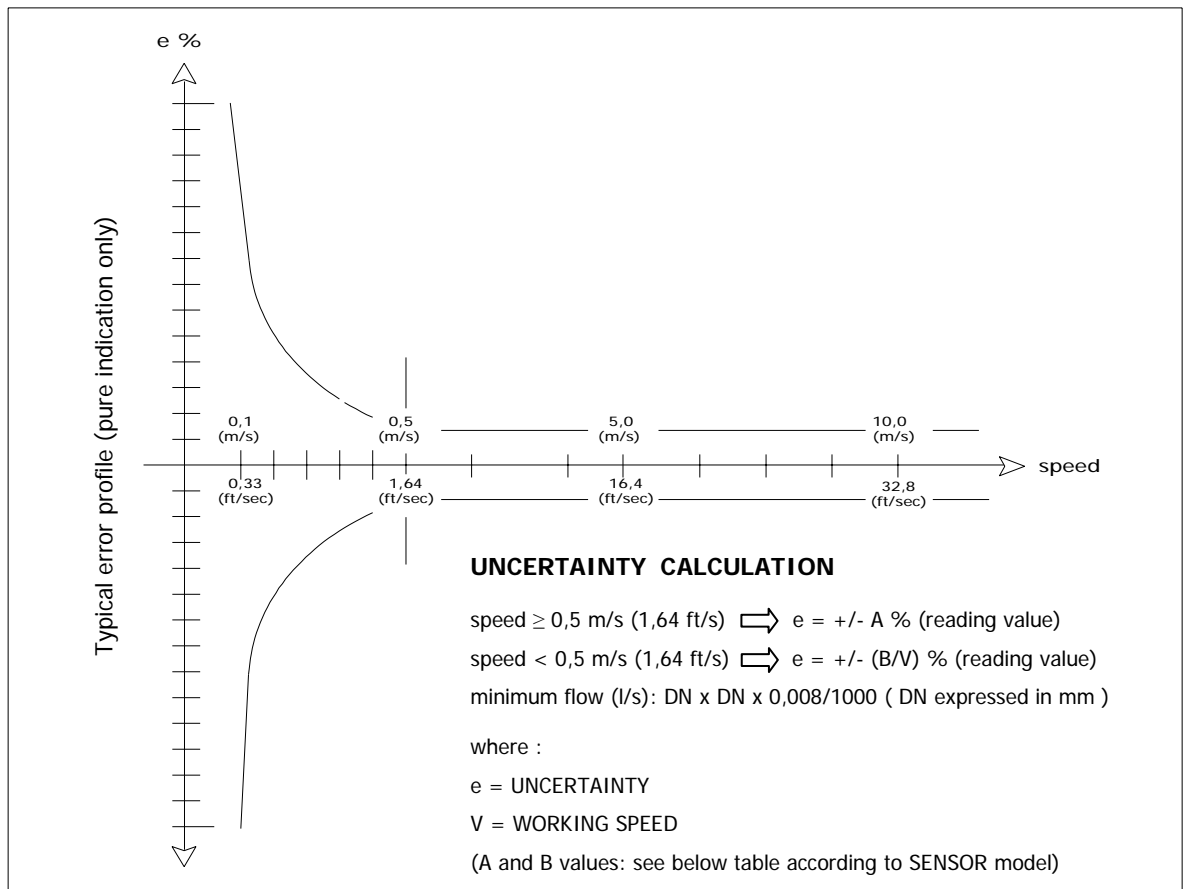

FULL BORE SENSORS

MS501/MS1000/MS2410/MS2500			MS 600			MS5000		
A	B(m/s)	B(ft/s)	A	B(m/s)	B(ft/s)	A	B(m/s)	B(ft/s)
0,8*	0,4**	1,31**	0,8*	0,4**	1,31**	2	1	3,28

* = 0,4 (special)

** = 0,2(m/s) ; 0,66(ft/s) - special

INSERTION SENSORS

MS3770			MS3800		
A	B(m/s)	B(ft/s)	A	B(m/s)	B(ft/s)
2	1	3,28	2	1	3,28

Reference conditions:

- Constant flow rate during the test
- Pressure: >30 Kpa
- Flow condition : fully developed flow profile
- Zero stability +/- 0,005 %

HOW TO ORDER

ML 110	Display
A	Blind execution (without display and programming keys)
B	Complete with 2 line back light display (each of 16 characters) and 3 programming keys
Housing material - Protection rate	
0	Nylon with glass fiber (IP 65)
1	Painted aluminum die casting, protection rate IP67
Version	
A	Compact version with sensor MS... (liquid maximum temperature 100 °C)
B	Separate version for wall mounting, complete with mounting accessories (C018 CABLE)
Power supply	
1	Power supply : 90 ... 265 V 45/66 Hz
2	Power supply : 18...63 V dc / 15...45 V ac - 45...66 Hz
9	Power supply : other
Analogue output	
A	Without analogue output
B	Analogue output 0/4...20/22 mA
Serial Interface	
1	None
2	RS485 Serial Interface
3	Modbus protocol over RS 485 interface
Accuracy	
A	Standard accuracy 0,8 %
B	Special accuracy 0,4 %
Special Features	
0	Any
1	With Anticondensing cap

ML 110 B 0 A 1 A 1 A 0

EXAMPLE OF CODE FOR ORDER

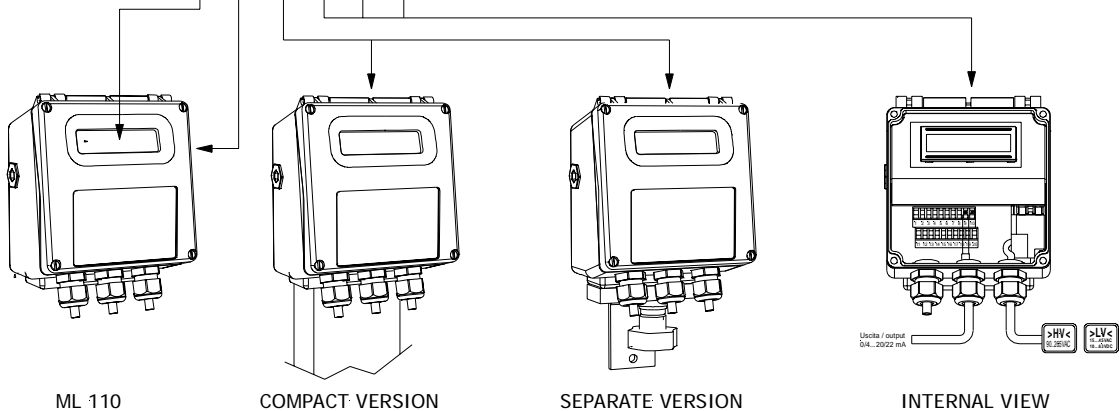

The manufacturer reserves the right to make design improvements without notice.